

It is of interest to note that the f^2 is approximately the same for solutions of approximately the same total ionic strength, which would be expected. Characteristically, the cadmium salt behaves quite differently from the others, which would be expected wherever the activity of the solution is a factor. Activity data⁸ show cadmium salts to behave very differently from others. The fact that the cadmium nitrate solution measured in this paper agrees with the other data seems to the authors a good confirmation of the theoretical aspects of the paper.

When unknown concentrations of both iodide and chloride are present, it is obvious that a single e. m. f. measurement applied in a modified form of equation (4) will be insufficient for the calculation of both unknowns. The data of Table I indicate that with a constant concentration of iodide, there is a systematic variation in e. m. f. with varying concentrations of chloride. There was no indication of the oxidation of the minute trace of iodide by the nitric acid, and the e. m. f. values became constant very rapidly.

Using the above procedure a sample of c. p. potassium nitrate was analyzed for chloride and was found to contain 0.00027% Cl. According

(8) Lewis and Randall, "Thermodynamics," McGraw-Hill Book Co., Inc., N. Y., 1923, p. 362.

to the analysis on the bottle there was less than 0.005% Cl. No satisfactory method could be found which would serve as a check on the value 0.00027%, but in view of the data put forward in this paper it was assumed to be correct.

Acknowledgment.—Gratitude is here expressed to the J. T. Baker Chemical Co. of Phillipsburg, N. J. The work on this problem was performed with the aid of the Eastern Research Fellowship in Analytical Chemistry established by them.

Summary

A rapid, accurate, electrometric technique for measuring quantitatively small amounts of substances which may occur as impurities in salts has been described, using as an illustration of the general method the determination of traces of chloride in a number of salts, by the use of silver-silver chloride electrodes. The method is comparable in accuracy with the nephelometric procedure, and possesses the advantage that foreign salts do not cause difficulties as they do in the use of the nephelometer. Traces of chloride of as low a concentration as 0.00035 g. of Cl⁻ per liter of solution were measured accurately by the method, in a variety of salts at various ionic strengths.

PRINCETON, N. J.

RECEIVED FEBRUARY 27, 1935

[CONTRIBUTION FROM THE FRICK CHEMICAL LABORATORY, PRINCETON UNIVERSITY]

A Comparison of Several Electrometric and Nephelometric Methods for the Estimation of Small Amounts of Chloride

BY N. HOWELL FURMAN AND GEORGE W. LOW, JR.¹

In the preceding paper there was discussed a method for the estimation of small amounts of chloride, which consisted in measuring the e. m. f. between two silver-silver chloride electrodes dipping into chloride solutions of different concentrations. It was pointed out that the nephelometric method ordinarily used for the estimation of small amounts of chloride is none too satisfactory, due chiefly to the fact that reproducibility of suspensions is difficult. The present paper describes the results obtained from the use of five different methods for the estimation of chloride, three of them electrometric (one of which was de-

(1) J. T. Baker Chemical Co. Fellow in Analytical Chemistry, 1933-1934.

scribed in detail in the preceding paper), and two nephelometric. For convenience in referring to them in the rest of the paper they shall be designated as follows: "the 0.01 excess method," "the small excess method," "the standard solution method," "the usual nephelometric method" and "the photronic nephelometric method." The same chloride solutions were measured by each of the five methods. Each solution was 0.3 *M* in nitric acid.

Apparatus and Materials.—The same precautions were taken, as described in the preceding paper, for the preparation of all the materials used. The same silver chloride electrodes were used, and all of the e. m. f. readings were made on the cali-

brated Queen potentiometer, Model E 3044, and at 25°. The nephelometric apparatus will be described in detail at a later point.

Procedures and Results.—An outline of each method will be given and then a comparison of the results will be made. In all of the electrometric methods a correction for slight differences in the electrodes was made in the manner described in the preceding paper.

1. **The 0.01 Excess Method.**—This method was described in detail in the preceding paper. The results are given in Table II.

2. **The Small Excess Method.**—This method is carried out in the same manner as method 1 except that the excess added is much less than 0.01 *M*, and is of the same order of magnitude as the unknown chloride concentration. In this way any complicated expression involving the solubility of the electrodes or the activity coefficients is avoided, since these factors are the same on each side of the concentration cell and therefore cancel out. The cell in this case is

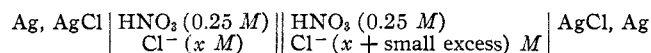

and the expression for the e. m. f. is therefore

$$E = 0.0591 \log [(x + \text{excess})/x]$$

In Table I are recorded the results obtained by this method, together with the excess of chloride which is used in each case. The chloride added is expressed as grams of chloride per liter in the 25.00-ml. portion taken as a sample, whereas the "excess added" is grams per liter in the 30.00-ml. portion, after the dilution. The method of making the solutions to be measured is exactly the same as described in the preceding paper, the only difference being in the excess chloride which is used.

TABLE I

THE SMALL EXCESS METHOD			
Excess added, g. per l.	Grams per liter of Added	chloride Found	E. m. f., v.
0.00040	0.00080	0.00075*	0.00702
.00100	.00400	.00392	.00685
.00100	.00500	.00508	.00545
.00100	.00600	.00615	.00457
.00400	.00800	.00802	.00204
.00400	.01000	.01020	.00990
.00400	.01200	.01198	.00865
.1000	.01800	.01799	.0523
.1000	.02000	.01968	.0503
.1000	.02200	.02191	.04795
.05000	.03600	.03550	.0254
.05000	.04000	.03953	.0237
.05000	.04400	.04364	.0222

There are two factors which must be considered in deciding what excess to use. The excess must be reasonably large so that the e. m. f. will be large also and can be read accurately. On the other hand, if the excess is too large, then the solubility of the electrodes becomes different on each side of the cell and instead of the simple equation for the calculation (which also leads to more accurate results) we are forced to use a complicated expression similar to equation 4 of the preceding paper. The data show that not as accurate results are obtained using the complicated expression as when using the simple one. However in the case marked (*) in Table I it is necessary to use a correction for the solubility of the electrodes in the solutions. This cannot be avoided since if we attempt to make the excess smaller, so that the solubility will be the same on each side of the cell, then we are faced with the problem of measuring accurately a very small e. m. f. which cannot be done on the type of potentiometer used in the present measurements.

3. The Standard Solution Method.

This method is similar to one used by Johnson and Low² for measuring the end-point of the potassium chloride-silver titration in a preliminary paper on the atomic weight of potassium. The e. m. f. of the cell used in this case is given by the expression

$$E = 0.0591 \log (x/\text{standard})$$

The results obtained by this method are given in Table II.

4. **The Usual Nephelometric Method.**—The nephelometric procedure was a standard method, as described by Kolthoff and Yutzy.³ The nephelometer was a black box type which is generally used in atomic weight work and has been described by Richards.⁴ In Table II are given the data.

5. The Photronic Nephelometric Method.

This method is radically different from any which has been heretofore described for reading the nephelometer. A photronic nephelometer has been described by Greene,⁵ but differs in principle from the one about to be described. For simplicity and ease of operation this method is very satisfactory.

The apparatus consists of a black box type nephelometer, similar to that used by Richards,⁴ with the end of the

(2) Johnson and Low, *J. Phys. Chem.*, **36**, 2390 (1932).

(3) Kolthoff and Yutzy, *THIS JOURNAL*, **55**, 1915 (1933).

(4) Richards and Wells, *Am. Chem. J.*, **31**, 235 (1904).

(5) Greene, *THIS JOURNAL*, **56**, 1269 (1934).

box which holds the test-tubes to be compared somewhat altered. The box is shown in Fig. 1. A is the light source, a 150-watt frosted bulb connected to 110-volt a. c. current. The two nephelometer tubes which are to be compared are placed in a sliding device, B (made of brass), so that either one of the tubes can be placed under the Weston photronic cell, P, by simply sliding B, which can be pushed easily with the hand. The tubes are protected from any

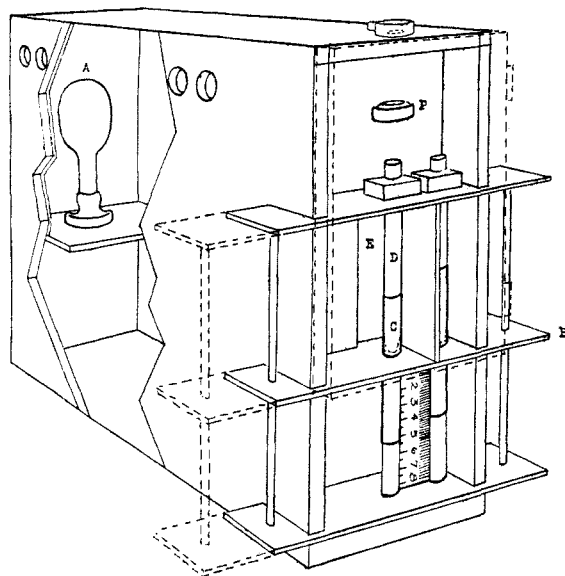

Fig. 1.—Photronic nephelometer.

stray light by carefully surrounding them with black pieces of wood so that any light which strikes the tubes comes from the light source, A, and through the opening, E. A door, indicated by dotted lines in the diagram, closes over the front of the box. The sliding collars, C (also made of brass), fit over the test-tubes and the amount of tube covered can be read on the scale. A very sensitive galvanometer is used for making the readings. The wiring diagram for the photronic cell and galvanometer is shown in Fig. 2. G is a Leeds and Northrup galvanometer No. 2290 with a sensitivity of 128 mm. per microvolt; P is a Weston photronic cell; S a single-pole single-throw switch; B a standard battery described in detail by Elliott and Hulett,⁶ which is a large Weston standard cell and will give a steady source of current; R_1 , R_2 , R_3 are resistances. The battery and photronic cell are connected to the galvanometer so that they cause it to deflect in *opposite* directions. This arrangement of the photronic cell in the nephelometer was developed only after many other attempts to apply two and finally one cell to the instrument were unsuccessful. At first an attempt was made to use two cells, one over each nephelometer tube, and by opposing these two cells against each other to obtain a comparison of the two tubes. This proved unsatisfactory owing to differences in the photronic cells and to the fact that there was considerable lag, and a different lag for each cell, in the response of the cell to the very faint light. Then it was attempted to measure the actual deflection caused on a galvanometer by one cell over one tube and

then over the other tube and in this way obtain a comparison of the suspensions in the tubes. This also proved unsuccessful owing again to the lag in the cell and the difficulty of comparing the deflections caused by the two tubes. Finally the technique of using the galvanometer as a "null" instrument was attempted and found to be quite successful.

A reading on this photronic nephelometer is made, then, as follows. One of the nephelometer tubes, D, for example the left one, is filled to the mark with a standard chloride solution whose concentration is known, and the right tube is filled with the unknown solution. The solutions are made up according to the procedure of Kolthoff and Yutzy, which is the same as described under method 4 of this paper. The sliding rack, B, is then pushed as far as it will go to the right, thus placing the tube containing the known amount of chloride under the photronic cell, P. The tube, C, is placed at an arbitrary setting of 50 on the scale. The switch, S, is then closed and the resistance, R_3 , varied so that the spot of light from the galvanometer comes to rest somewhere near the middle of the galvanometer scale. With the switch, S, still closed the rack, B, is then pushed over to the left position so that the right tube containing the unknown amount of chloride, is under the photronic cell. If the spot on the galvanometer scale changes position, it shows that the sliding collar, C, on the unknown should be changed; this setting is then changed continually until the spot on the galvanometer scale remains in exactly the same position no matter which nephelometer tube is under the photronic cell. The turbidities in the two tubes are then inversely proportional to the amount of tube exposed to the light, provided the known and the unknown are not too far apart in intensity. In actual practice it was found more satisfactory to use the method suggested by Kolthoff and Yutzy, *i. e.*, the "tare" method of making the readings. First both tubes are filled with the known solution, a reading is made, then the left tube is allowed to remain unmoved while the unknown solution is placed in the right tube and another reading made. This method of making readings eliminates any small instrumental error since the two turbidities are compared under identical conditions.

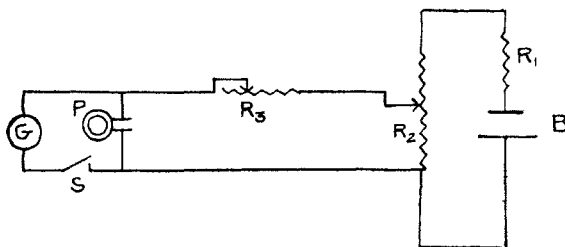

Fig. 2.—Wiring diagram for photronic nephelometer: B, "bull cell," 1.0183 volts; R_1 , resistance, 10 megohms; R_2 , variable resistance, 0–200,000 ohms; R_3 , variable resistance, 0–20,000 ohms; P, photronic cell; S, single-pole single-throw switch; G, galvanometer.

The results obtained by this method showed the instrument to be much more accurate and dependable than the method of making the suspensions. Suspensions reproducible to an ac-

(6) Elliott and Hulett, *J. Phys. Chem.*, **37**, 489 (1933).

curacy of better than 3 or 4% were not possible, whereas the readings on the instrument could easily be made with an error of no more than 0.5% and there is no reason why the instrument could not be refined to give a better accuracy still. However, the present methods of making nephelometric suspensions do not justify the use of too accurate an instrument for comparing them. The photronic method of reading the nephelometer possesses the advantage of speed in making the readings, and it should also prove of value in studying the reproducibility of suspensions. As the technique for producing better suspensions is developed the photronic nephelometer should become more useful since the reading error is much less than with the visual method of reading.

Comparison of the Different Methods.—

Table II is a compilation of the results obtained from the five different methods of measuring the chloride concentration of the same solutions. All of the concentrations are expressed as grams per liter of solution.

TABLE II

SUMMARY OF RESULTS

Std. indicates that the solution in that row was used as a standard of comparison for the solutions above and below it in the table.

Chloride added	Chloride Found				
	Electrometric			Nephelometric	
	0.01 Excess method	Small excess method	Std. soln. method	Usual	Photronic
0.00080	0.00060	0.00075	0.00082	0.00070	0.00082
.00100	.00098		Std.	Std.	Std.
.00120	.00114		.00120	.0013	.00126
.00400	.00416	.00392	.00404	.0039	.00414
.00500	.00516	.00508	Std.	Std.	Std.
.00600	.00635	.00615	.00596	.0061	.00604
.00800	.00821	.00802	.00807	.0076	.00816
.01000	.01039	.01020	Std.	Std.	Std.
.01200	.01250	.01198	.01210	.0120	.01160
.01800	.01881	.01799	.01807	.0180	.01820
.02000	.02030	.01968	Std.	Std.	Std.
.02200	.02205	.02191	.02204	.0230	.02100
.03600	.03611	.03550	.03615	.0350	.03790
.04000	.04050	.03953	Std.	Std.	Std.
.04400	.04394	.04364	.04428	.0460	.04190

1. **Accuracy.**—As can be seen from an inspection of the data, the most accurate method is the electrometric "standard solution method." Unfortunately this is also the most inconvenient to use due to the necessity for making chloride-free standards, but in work where a high degree of accuracy is required, such as in atomic weight work, this method is extremely valuable, as has

been shown by Johnson and Low,² who originally suggested this technique. The small excess method is much more accurate than either of the nephelometric procedures and is almost as accurate as the standard solution method, and is by far the most satisfactory to use.

2. **Ease and Speed of Operation.** Approximately one and one-half hours are needed to make a nephelometric determination, counting the hour the solutions must stand in the dark before the reading can be made. This is to be compared to the twenty minutes, at most, it takes to determine the chloride in an unknown sample by any of the electrometric procedures. For ordinary work where the range of chloride to be determined is known the small excess method is definitely to be preferred.

3. **Range of Applicability.**—The electrometric methods can be used for much higher concentrations than the nephelometric and for equally low ones, although at very low concentrations the solubility of the electrodes is a complicating factor which must be considered. As far as determining substances other than chloride is concerned, the nephelometric technique is, of course, at present much more widely used. However, as pointed out before, it seems reasonable that any substance for which a suitable reversible electrode could be found could be determined in the same way as described for chloride in this and the preceding papers.

Acknowledgment.—Gratitude is here expressed to the J. T. Baker Chemical Co. of Phillipsburg, N. J. The work on this paper was performed with the aid of the Eastern Fellowship in Analytical Chemistry established by them.

Summary

A comparison of five different methods of estimating small amounts of chloride quantitatively has been made—three electrometric and two nephelometric. The conclusion reached is that the electrometric methods are more accurate, easier to perform, less time consuming, and in general more satisfactory. A new photronic nephelometer has been described, which confirms the general experience with nephelometers that the chief difficulty lies in the reproducibility of the suspensions.